

Sterilight®

ULTRAVIOLET DISINFECTION SYSTEM

model S24Q & S24Q-GOLD

The S24Q and S24Q-GOLD disinfection systems were specifically designed for both residential and commercial/industrial applications requiring a 99.99% reduction of bacteria, virus and protozoan cysts (*Giardia lamblia* and *Cryptosporidium*). This process is accomplished without adding any harmful chemicals to your drinking water. Sterilight is the most ecological way of treating your water... *and all this for just pennies a day!*

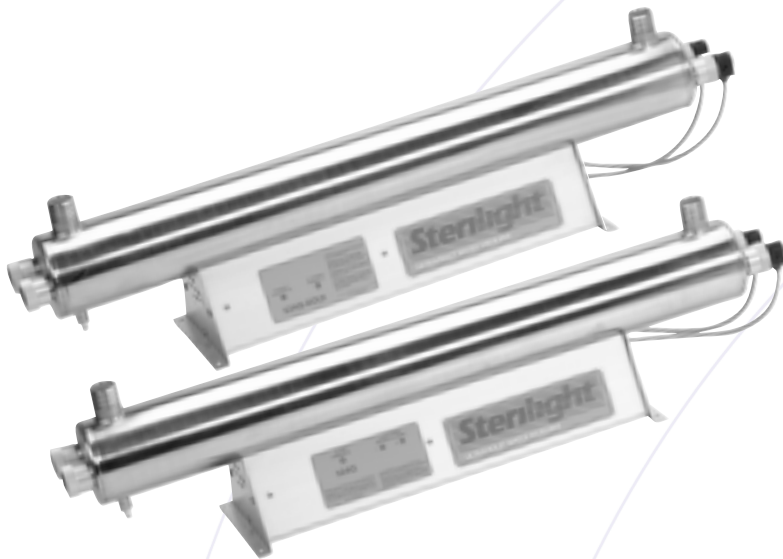

In addition to bacteria (*E. coli*), virus, algae, mould and others, Sterilight UV systems are effective against protozoa such as *Cryptosporidium* and *Giardia lamblia*. UV effectively **DESTROYS** these **protozoan cysts** at dosage levels well within the levels delivered by all Sterilight ultraviolet disinfection systems.

- high flow 113.6 L/min (30 gpm) at 95% UVT
- **Sterilume™-EX** UV lamps, these hard glass, 254nm ultraviolet lamps feature advanced proprietary lamp coating allowing for consistent UV output over the life of the lamp coupled with uniform temperature distribution. The result is that Sterilume™-EX lamps provide the required output over the entire 9000 hour lamp life
- 316L stainless steel reactor chambers, brilliantly polished for laboratory or medical applications
- 1" MNPT connections for quick and easy installation
- easy servicing – no need to disconnect water flow to change UV lamp
- open end quartz sleeve and aluminum gland nuts for optimum operating temperature and sealing efficiency
- drain port for reactor chamber flushing
- 99.99% destruction of bacteria, virus and protozoan cysts (*Giardia lamblia* and *Cryptosporidium*) at rated flow
- nature's way to protect your water without the addition of harmful chemicals
- seven year warranty on reactor chamber for unparalleled protection
- "GOLD" series includes true 254nm UV monitors, solenoid output (solenoid valve not included) and infrared output for remote monitoring and diagnostic testing
- visual lamp-on indicator and audible lamp failure indicator
- "easy access" aluminum base for quick and easy servicing

ensuring the safety of your water

model S24Q AND S24Q-GOLD

Additional S24Q-GOLD Features

UV Monitor – a true 254 nm ultraviolet sensor incorporating individual calibration boards (allows for field replacement of sensor components, if necessary) – audible and visual indicators included as integral components.

Solenoid Output – works in conjunction with the ultraviolet alarm allowing for the stoppage of water flow in the event that the sensor detects that the water is not adequately being treated or in case of a power failure – to be used in conjunction with optional normally – closed solenoid valves.

Infrared Output – allows for remote monitoring as well as a diagnostic tool for service technicians (microcontroller incorporated into the circuitry to keep track of actual UV intensity and elapsed running time). For remote audible and visual monitoring of the UV sensor, use the optional IR-ALARM.

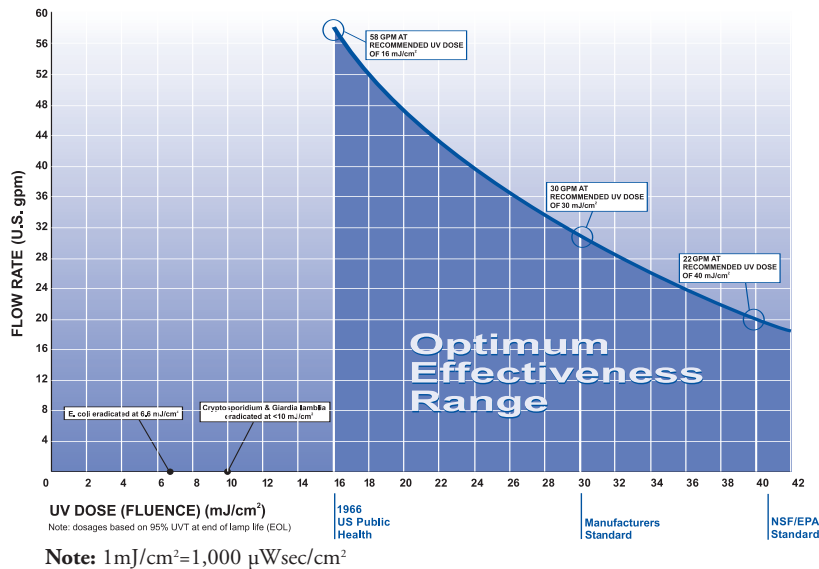

SPECIFICATIONS S24Q and S24Q-GOLD

Flow Rate (Dose Dependent)		
16 mJ/cm ² (US Public Health)		219.6 L/min (58 gpm) (13.2 m ³ /hr.) ¹
30 mJ/cm ² (R-Can Standard)		113.6 L/min (30 gpm) (6.8 m ³ /hr.)
40 mJ/cm ² (NSF/EPA)		83.3 L/min (22 gpm) (5.0 m ³ /hr.)
Dimensions	Length	94 cm (37")
	Width	17.8 cm (7")
	Height	24.1 cm (9.5")
	Cell Dia.	10.2 cm (4")
Shipping Weight		S24Q – 10.5 kg (23 lbs.) S24Q-GOLD – 10.9 kg (24 lbs.)
Electrical	Voltage	100-130 V./50-60 Hz. ²
	Total Watts	95 W
	Total Lamp Watts	78 W
Maximum Operating Pressure		8.62 bar (125 psi)
Ambient Temperature Range		2 - 40° C (36 - 104° F)
Quartz Sleeve		Yes (2)
Inlet/Outlet Port Size		1" MNPT
Lamp Failure	Visual	Yes
	Audible	Yes
254 nm UV Monitor		Yes (for S24Q-GOLD)
Solenoid Output		Yes (for S24Q-GOLD)
Infrared Output (Remote Alarm)		Yes (for S24Q-GOLD)
Reactor Chamber Material		316L S.S.

- Note: At this flow rate, a pressure drop of approximately 10 psi will be realized
- 200-250 V./50-60 Hz. available on request (add "/2" to model # (eg. S24Q/2))

Optional Items



Cable
CS-MOL, used to connect solenoid to unit

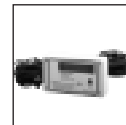

Remote Alarm
IR-ALARM, remotely (50') displays UV intensity (55-99%) & elapsed running time



Flow Restrictor
FR-20, 20 gpm restrictor, 1" x 1" FNPT, chrome plated



Solenoid Valve
SOL-1.0, 1" brass (110 V.), SOL-1.0/2, 1" brass (240 V.)

Warranty Sterilight S24Q and S24Q-GOLD water disinfection systems carry a seven year warranty on the stainless steel reactor chamber, a one year warranty on UV lamps, quartz sleeves, and monitor probes, and a five year pro-rated warranty on all other components.

Replacement Parts

S36RL – replacement UV lamp (2 required)

QS-012 – quartz sleeve (2 required)

OR-212 – o-ring for quartz sleeve

254NM-09 – UV sensor for S24Q-GOLD

BA-E36122 – electronic ballast (100-250V./50-60Hz.)

R-can
ENVIRONMENTAL INC

425 Clair Rd. West, P.O. Box 1719
Guelph, Ontario, Canada N1H 7X4
t. 519.763.1032 • f. 519.763.5069
t.f. 1.800.265.7246
www.r-can.com • water@r-can.com

EPA Establishment #57987-CN-001
U.S. Patent #6274988



For further information contact:



PRINTED IN CANADA
LIT-0102106

Revised 07/04
Copyright 2004
R-Can Environmental Inc.
All rights reserved.